

OVERHEAD PROVERS

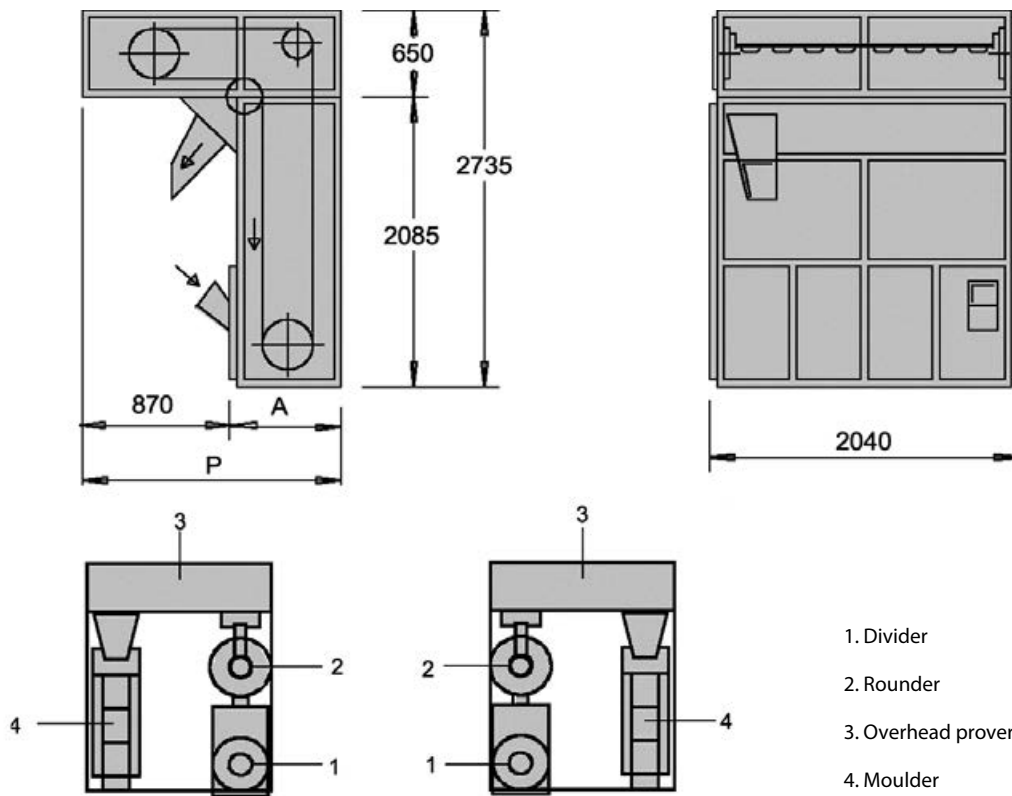

- St/st carters
- Slopes and collecting drawers in st/st
- Painted steel frame
- Regular overturn of pieces from row to row
- Single nylon pockets easy to remove for ordinary cleaning
- Germicide lamp
- Heating unit with automatic thermostat
- Photocell synchronized speed
- C8T intermittent working: speed is synchronised with divider by photocell
- C8T continuous working: speed is adjusted electronically by inverter (pockets and infeed belt).
When matched with divider SV200 + k3 keyboard or computer, speed is synchronised automatically to SV200 speed
- Switch for continuous working
- Timer for resting time selection in manual cycle



	Weight per piece	Pocket swinging trays	Production	Dimensions		Power	Weight	Voltage
				A	P			
	g	n°	pezzi/ora	mm	mm	kW	kg	V/~Hz
CT 160	300÷1200	160	960 ÷ 2000	850	1720	2,5	550	V400/3~/50Hz
CT 240	300÷1200	240	960 ÷ 2000	1480	2350	2,5	1000	V400/3~/50Hz
CT 304	300÷1200	304	960 ÷ 2000	1480	2350	2,5	1200	V400/3~/50Hz
CT 384	300÷1200	384	960 ÷ 2000	2170	3040	2,5	1450	V400/3~/50Hz
CT 448	300÷1200	448	960 ÷ 2000	2170	3040	2,5	1650	V400/3~/50Hz